



Redesigned Helios Gate Valve

The Solutions Company



Helios-Reactor Gate Valve

- Designed to far exceed latest OEM specification
- Tested 100% for operational precision
- Drop in replacement for OEM style valve
- Linear motion to sealing surface (no O-ring roll / particles)
- Gate moves completely out of (below) and away from the wafer line
- No direct light energy on the sealing surface (O-ring) when open
- O-ring maintenance reduced from 4 hours to 30 minutes
- Easily serviceable / self aligning replaceable gate sealing surface – rapid/ reliable and repeatable maintenance
- All bearings are O-ring sealed for cleanliness
- Gate seal meets O-ring 'compression' standards
- SS gate bench He leak check capable
- Each gate valve factory tested
- **1.5 year warranty**

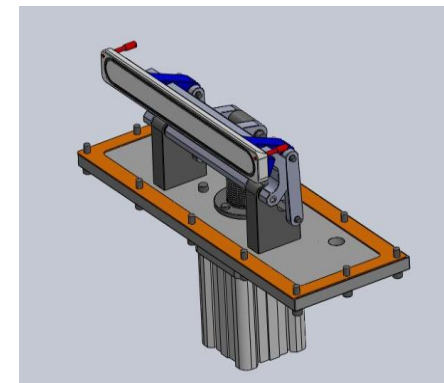
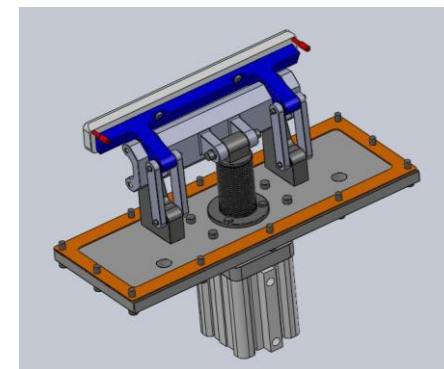
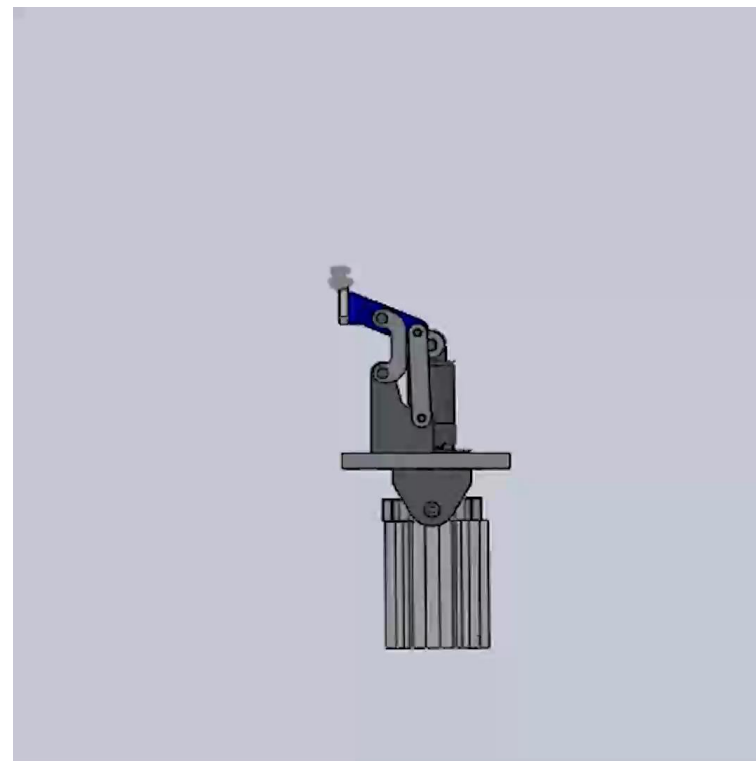

Resolve leaking and particle issues with our high quality, cost effective reactor gate valve

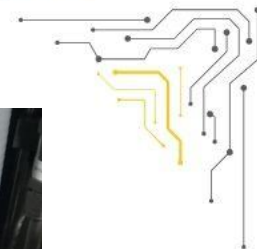

Helios-Reactor Gate Valve

Areas redesigned with Engineering precision:

- Drop in replacement for OEM style valve
 - All OEM plumbing is maintained (*)
 - Pneumatic and electrical connections are 'plug and play'
- Linear motion to sealing surface (no O-ring roll / particles)
 - Specially designed Helios gate motion
 - Significantly reduced particles
- Gate moves completely out of (below) and away from the wafer line
 - Improves maintenance clearance in Theta
- No direct light energy on the sealing surface (O-ring) when open
 - Moves open gate O-ring out of direct lamp radiation – improves lifetime

*Based on OEM standard plumbing, or custom plumbing required



All dimensions and manufacturing techniques are proprietary to Helios





Helios-Reactor Gate Valve

Areas redesigned with Engineering precision:

- Easily serviceable / self aligning replaceable gate sealing surface – rapid/reliable maintenance
 - Reactor Gate is machined to extremely tight tolerances for highly repeatable and consistent replacement
 - O-ring maintenance reduced from 4 hours to 30 minutes, can store Reactor Gate with new O-ring, and leak check – on demand
- All bearings are O-ring sealed for cleanliness
 - Helios developed needle bearing joints and O-ring seals for WHC cleanliness
- Gate seal meets O-ring 'compression' standards
 - Many OEM valves are known to leak at ATM and RP
 - OEM valve did not meet the standard 20% compression standard
 - O-ring contact patch is 6X improved from OEM



All dimensions and manufacturing techniques are proprietary to Helios



Helios performance compared to OEM

Parameter	OEM Performance	Helios Performance	Detail
Sealed O-ring deflection (closed)	<10%	20% (per Engineering standard)	Helios gate has 6X greater sealed contact patch
Closing gate motion Z	Perpendicular <0.070" (1.78mm)	Perpendicular <0.003" (0.07mm)	Helios eliminates O-ring roll
O-ring degradation from lamp radiation	Light exposure while open 100%	Light exposure while open <10%	Any color O-ring can be used
Time, O-ring replacement	Average 4 hours	Average 30 minutes	800% better

